

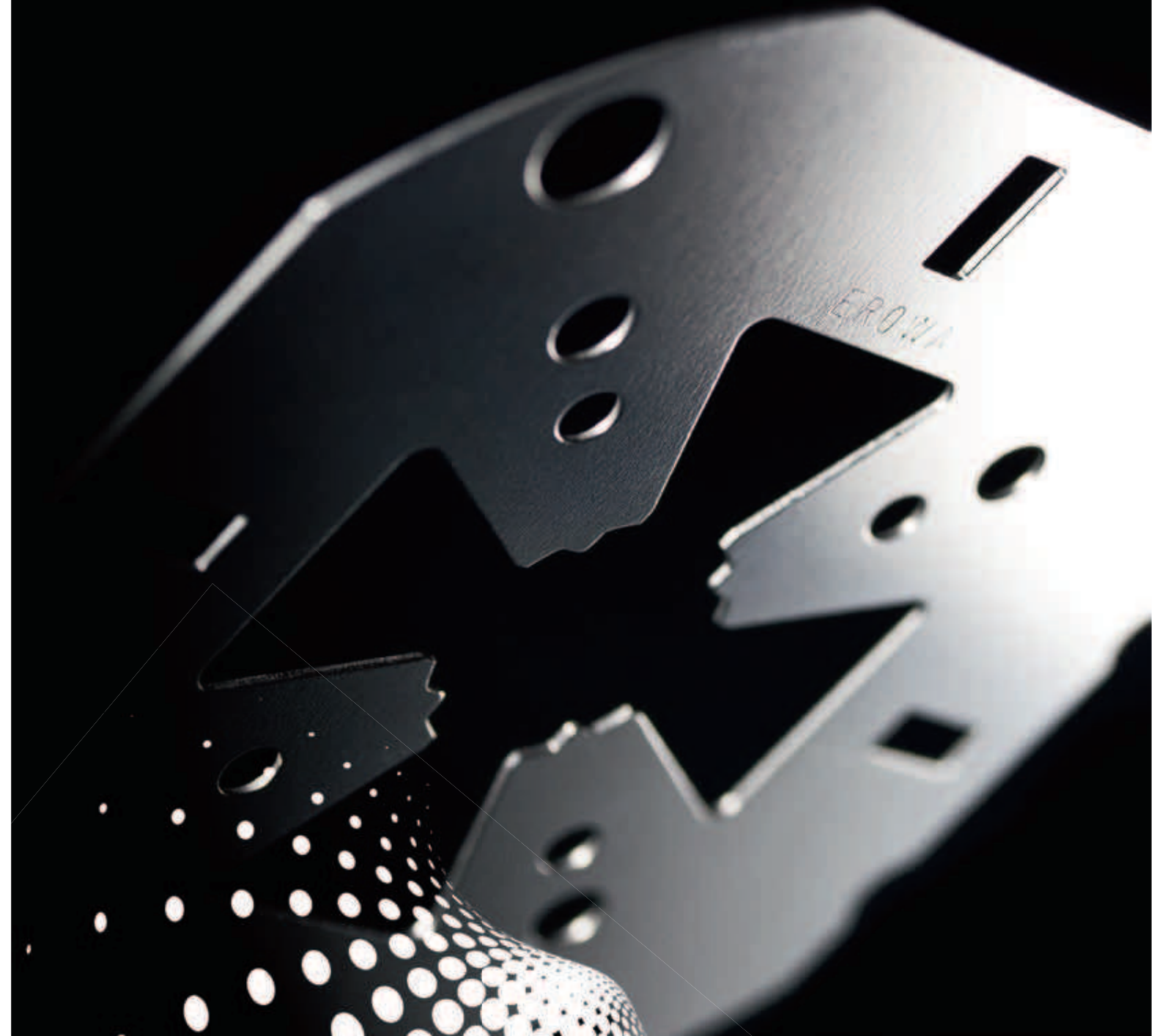

General Catalog

Unlocking the full potential
of your machines



EROWA ITS Compact Combi

Three in one

Seamless integration into the existing ITS system. The ITS Compact CombiChucks have the same mounting borehole grid as the conventional EROWA ITS chucks. Universal clamping of three systems in one single chuck. High precision and great performance due to the patented EROWA tooling technology. Whether on the machine table or in the tool quill: EROWA's ITS Compact CombiChucks can be used everywhere.

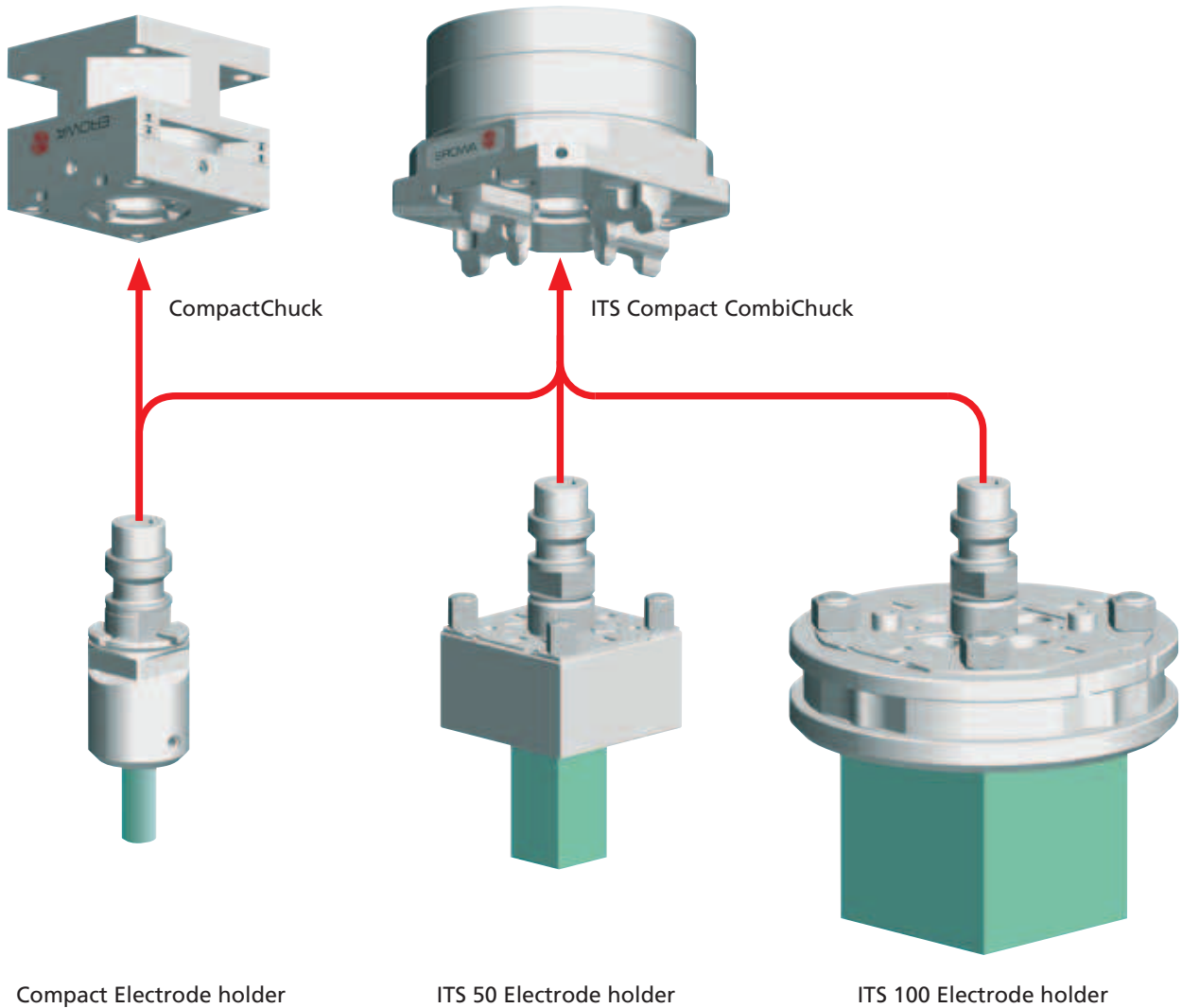

Applications



Handling

Manual / Loading facility / Robot

Function

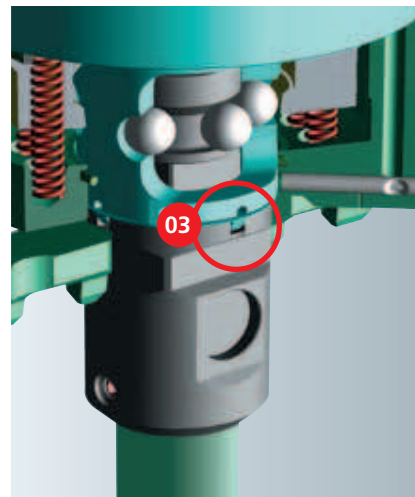
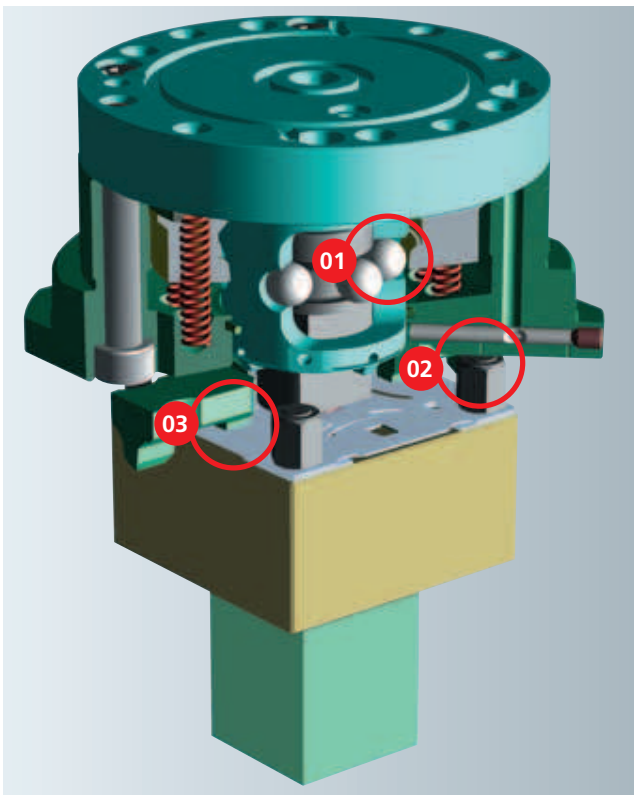

ITS Compact CombiChuck with Compact holder.

01 | Ball-lock

The self-locking ball-lock generates a clamping power of 5,000 N (with re-clamping) and does not open even if the pressure fails.

ITS Compact CombiChuck with ITS holder.

02 | Cleaning

The support feet are cleaned during the clamping process.

03 | Prismatic spigots

After latching to the centering plate, the prismatic spigots in combination with the spring slots ensure powerful and high-precision positioning.

Technical data - ITS Compact Combi Chuck

	ITS Compact CombiChuck
System sizes	Compact 30, ITS 50 and ITS 100
Indexing	4 x 90°
Clamping power	3,000 N, 5,000 N with reclamping
Clamping	Spring power
Opening	Compressed air min. 6 bar
Operation	With manual or electropneumatic control unit

EROWA ITS Compact Combi in action

Versatile and universal

Compact – the best investment value tooling system for electrodes up to \varnothing 50 mm. Compactness, precision, great performance. EROWA's Compact System consists of a complete range of chucks, electrode holders, electrode changers and accessories.

FLEXIBLE

Universal clamping of three systems in one chuck.

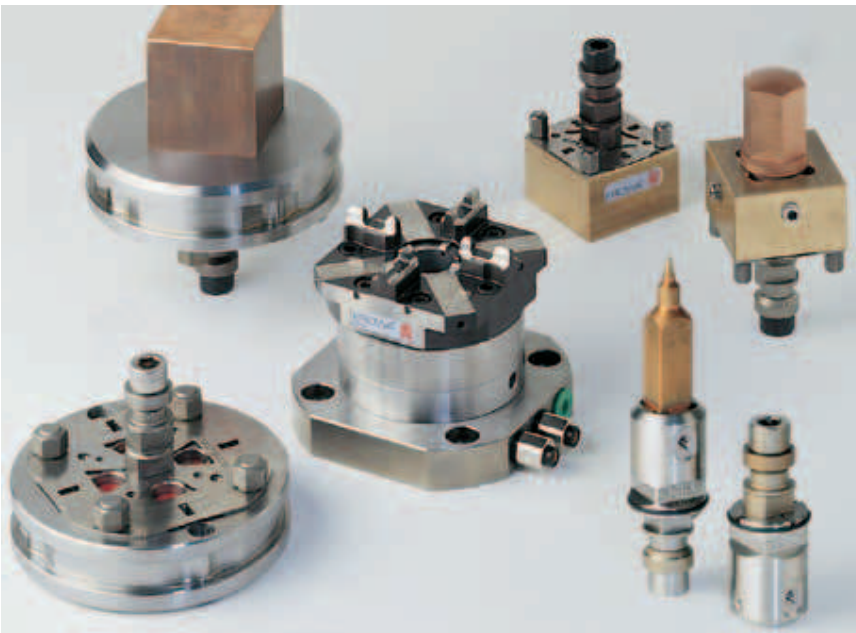

Three pallet sizes - one chuck.
EROWA ITS Compact CombiChuck.

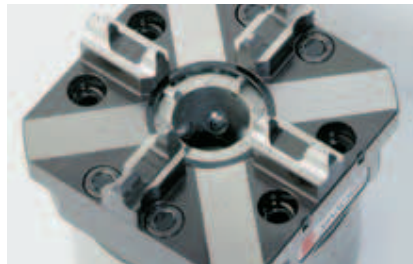

Storage capacity of up to 900 parts per square meter.



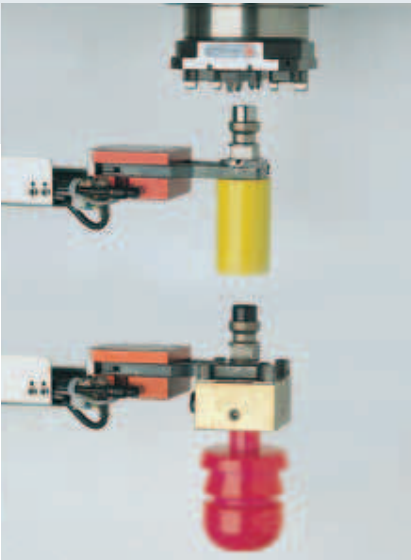

Economical automation by a combined loading of the EDM center.

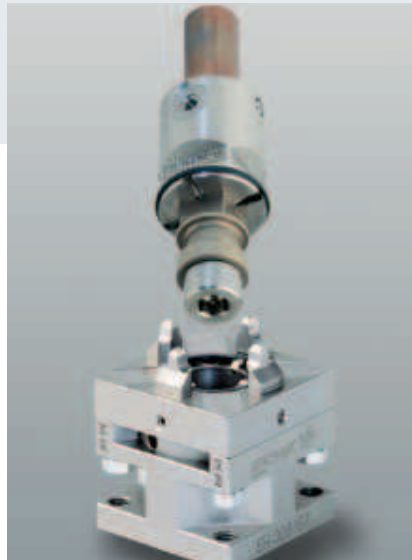

Quick and precise clamping of electrode holders with a fitted chip guard.



Compact chucking spigot Combi: for the integration of all Compact electrodes and electrode holders into the EROWA ITS Compact Combi system.

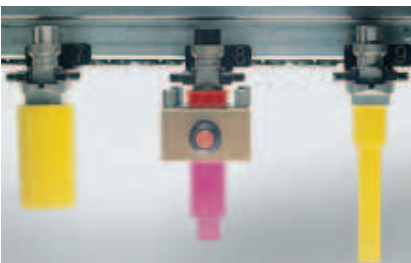

Mixed up in the electrode magazine.



Compact ITS Adapter for the integration of Compact holders into regular ITS chucks.



Robust and precise. The Compact standard holder is the base for most clamping applications.



Ready - steady - GO! Insert chucking spigot and start machining. Use the ready made copper blank, you won't find a quicker way.



With a Compact ITS adapter, Compact electrode holders become compatible with regular EROWA ITS chucks. The electrode holder can be manually clamped in the adapter with precision and speed.

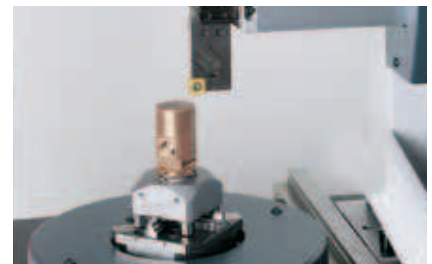

Setting-up and measuring outside the machine: quick!, simple and accurate.



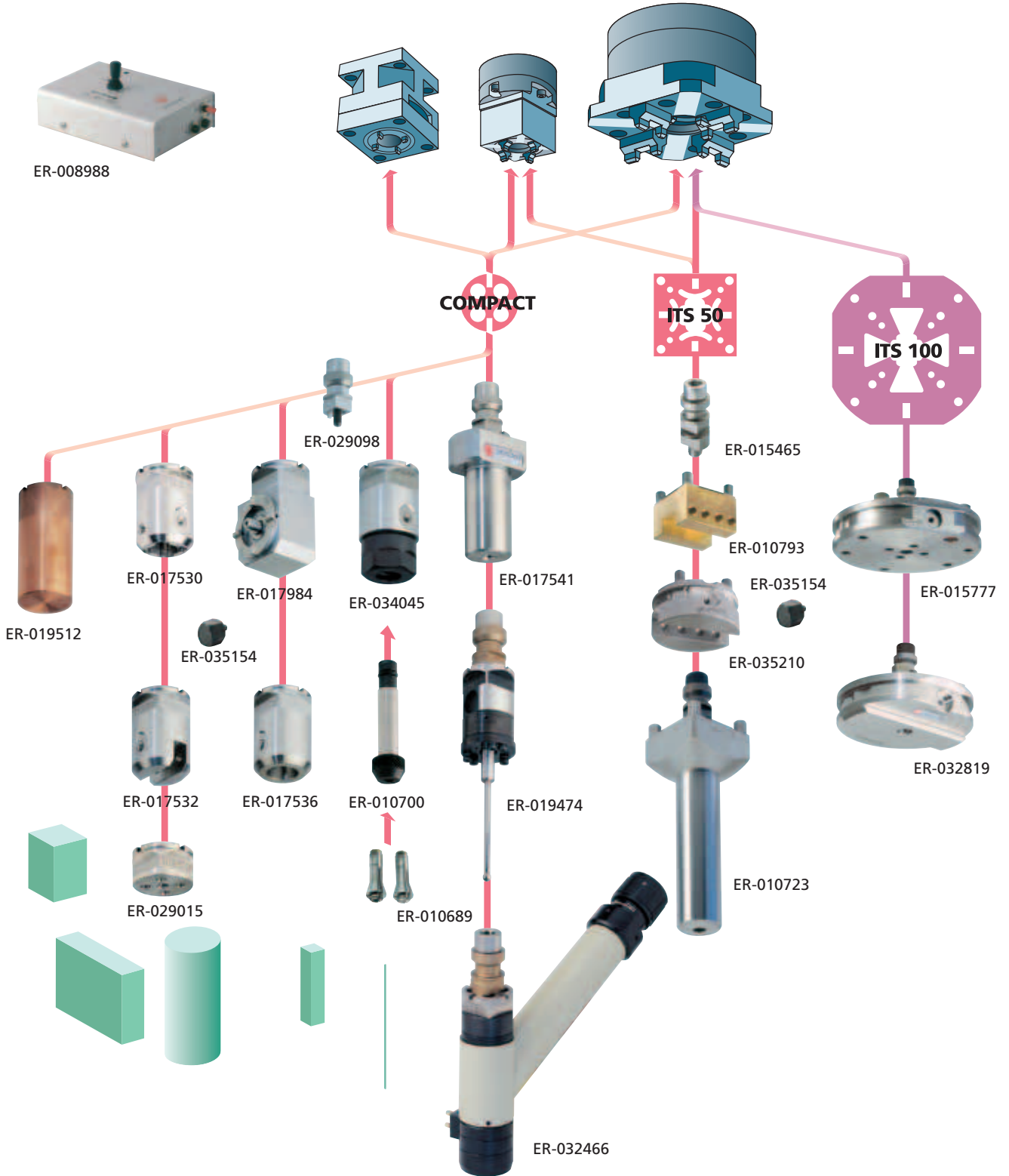













EROWA ITS Compact Combi Tooling system The components



To make it easier for you to find your way about the fields of application for EROWA products, we use the following symbols in all our documents:



EROWA ITS COMPACT COMBI TOOLING SYSTEM

1. Manual operation 
2. Operate with compressed air jet 
3. Operate with manual valve 
4. Operate with manual control unit 
5. Operate with electro-pneumatic control unit 
6. With central flushing clearance 
7. Suited for submerged operation 
8. Corrosion-resistant material 
9. Suited for automatic operation 
10. Handling with EROWA Robot gripper S 
11. Handling with EROWA Combi gripper 
12. Handling with EROWA Robot gripper 72 
13. Handling with EROWA Robot gripper 115 
14. Handling with EROWA Robot gripper 148 
15. Handling with EROWA gripper RN PC 210 
16. Handling with EROWA RCS gripper 

ITS Compcat Combi	a survey	188
ITS Compcat Combi	ITS Compact CombiChuck	190
ITS Compcat Combi	Compact chuck	194
ITS Compcat Combi	Compact ITS Adapter	195
ITS Compcat Combi	Electrodeholder	196
ITS Compcat Combi	Electrode	198
ITS Compcat Combi	Accessories	199
ITS Compcat Combi	Measuring equipment	202
ITS Compcat Combi	Compact Electrodeholder Set	204



For chip-removing processes



For EDM sinking



For WEDM

EROWA ITS Compact Combi Tooling system

The chucks



pneumatically operated

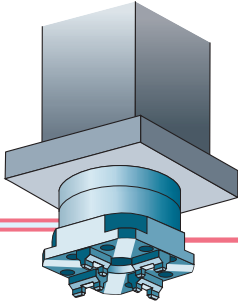

Quill chuck



ER-020025



ER-020026



ER-035261



ER-035262

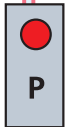
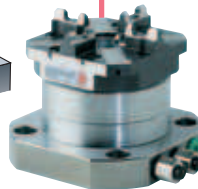
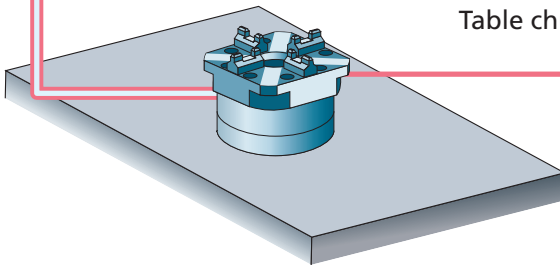

Table chuck



ER-020027



ER-020963

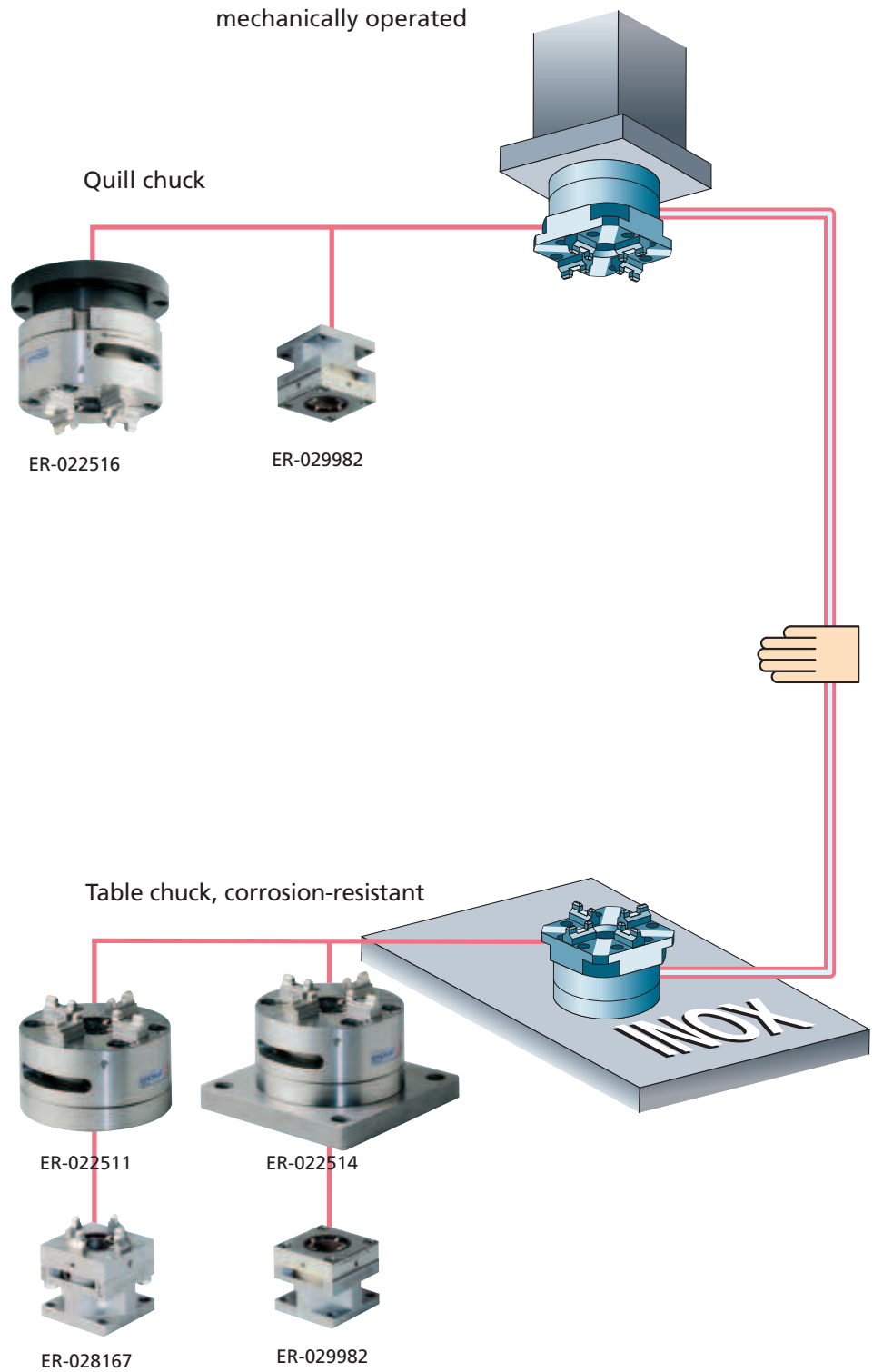

ITS Compact Combi

EROWA ITS Compact Combi Chucks

Technical data	ITS Compact CombiChuck	ITS 50 Compact CombiChuck
Repeatability	0,002 mm	0,002 mm
Indexing	4 x 90°	4 x 90°
Clamping power with re-clamping 6 bar (without)	5000 N (3000 N)	(4'000 N)
Generated by	springs	springs
Opening with compressed air, dry	min. 6 bar	min. 6 bar
Operation	with manual or electro-pneumatic control unit.	with manual or electro-pneumatic control unit.

ER-020025 ITS Compact CombiChuck



Version ITS rapid-action chuck with built-in CompactChuck.
 Connections At the rear.
 Application EDM centers with automatic electrode change, machine tools with automatic loading of ITS and Compact electrode holders.

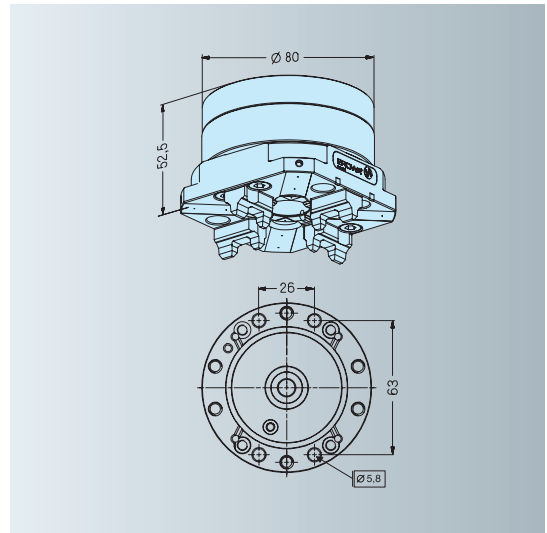

ER-020026 ITS Compact CombiChuck with collar



Version With flange \varnothing 80/55 mm for flushing connection.
 Connections At the rear.
 Application EDM centers with automatic electrode change of ITS and Compact electrode holders.

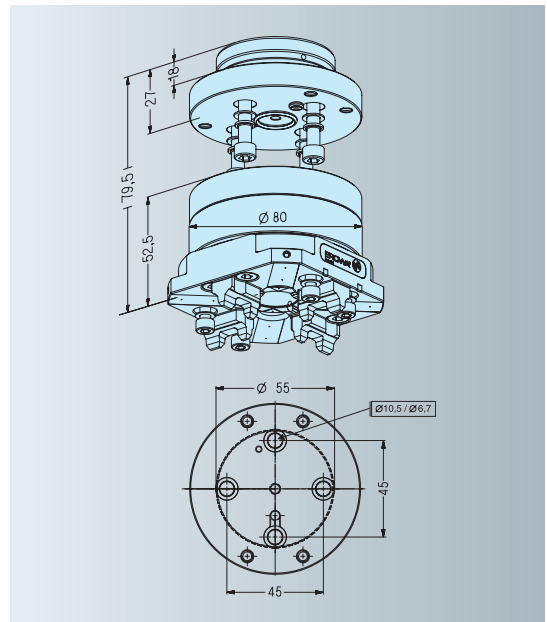

ER-035261 ITS 50 Compact CombiChuck

Version ITS QuickChuck 50 with built-in CompactChuck.
 Connections At the rear.
 Application EDM centers with automatic electrode change, machine tools with automatic loading of ITS and Compact electrode holders.

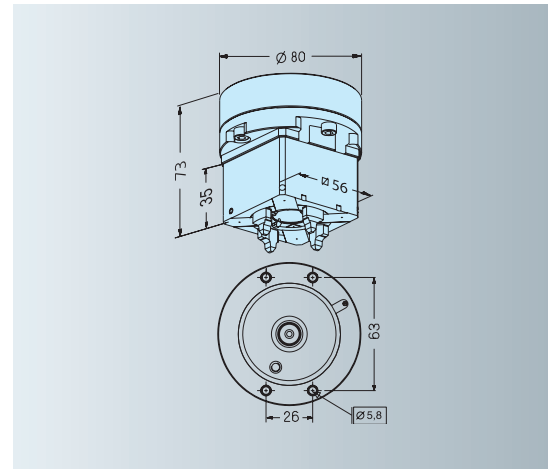
**ER-035262 ITS 50 Compact CombiChuck with collar**

Version With flange $\varnothing 80/55$ mm for flushing connection.
 Connections At the rear.
 Application EDM centers with automatic electrode change of ITS and Compact electrode holders.

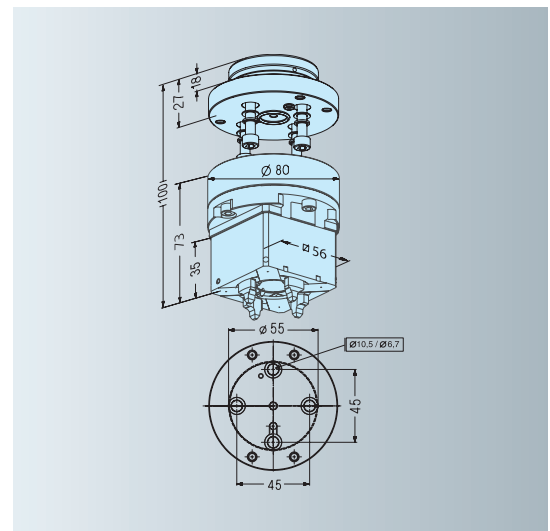
**ER-020027 ITS Compact CombiChuck with clamping pallet**

Version With clamping pallet 106 x 106 mm.
 Connections With lateral clamping plate for manual and pneumatic control unit.
 Application On milling, grinding and EDM centers with manual and automatic loading facilities.

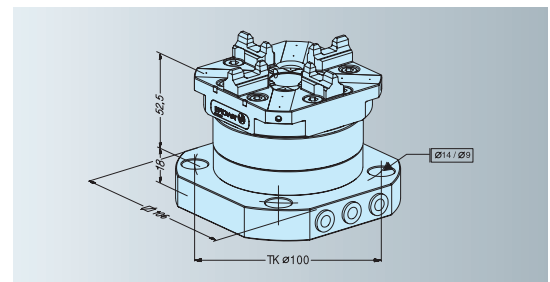

EROWA ITS Compact Combi Chucks

Technical data	QuickChuck 100 Combi	QuickChuck 50 Combi
Repeatability	0,002 mm	0,002 mm
Indexing	4 x 90°	4 x 90°
Max. clamping power	up to 10'000 N	up to 4'000 N
Operation	manual	manual

ER-022511 QuickChuck 100 Combi



Version Combi system for EROWA ITS and Compact.
 To fit With 4 x M8 bolts.
 Operation Manual.
 Application To clamp EROWA electrode holders and pallets of the system sizes Compact, ITS 50 und ITS 100.

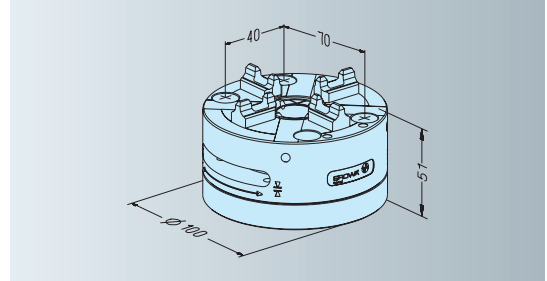

ER-022514 QuickChuck 100 Combi with base plate 125x125



Version Combi system for EROWA ITS and Compact with base plate.
 Mounting With bolts or brackets.
 Operation Manual.
 Application To clamp EROWA electrode holders and pallets of the system sizes Compact, ITS 50 and ITS 100.

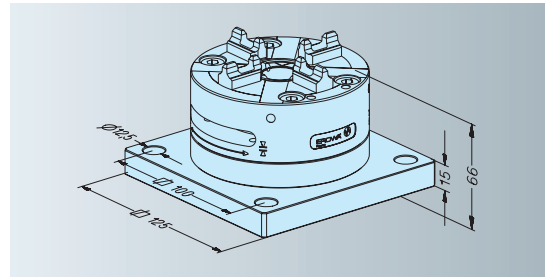

ER-022516 QuickChuck 100 Combi R



Version Combi system for EROWA ITS and Compact with rotatable flushing connection.
 Mounting With 4 x M6 bolts.
 Operation Manual.
 Application To fit to rotating axes of EDM centers with lateral flushing connection.

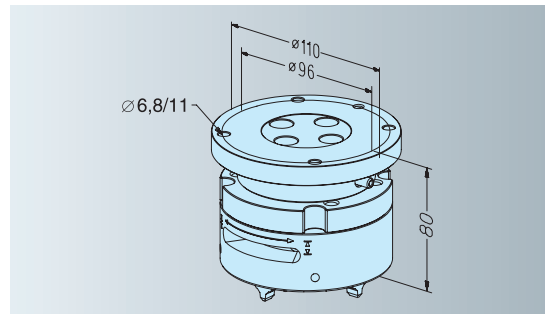

ER-028167 QuickChuck 50 Combi

Version	Combi System for EROWA ITS and Compact.
Mounting	With four M8 bolts or four M6 bolts and nuts.
Operation	Manual.
Application	Clamping of EROWA electrode holders of the system size Compact and ITS 50.

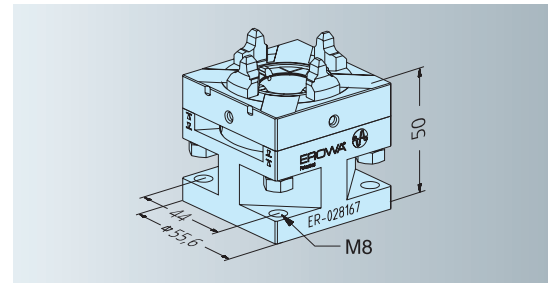

EROWA ITS Compact Combi

Compact chucks

Technical data	CompactChuck
Repeatability	0.002 mm
Indexing	4 x 90°
Clamping power with reclamping 6 bar (without)	5,000 N (2,200 N)
Opening with compressed air	min. 6 bar
Operation mode	PA = Pneumatic, automatic PM = Pneumatic, manual M = Manual

ER-029982 CompactChuck M



Mounting	With four M8 bolts or with four M6 bolts and nuts
Operation	Rapid-action lock with lever.
Application	Clamping of EROWA Compact electrode holders.
Note	The CompactChuck M can also be used as a quill chuck.

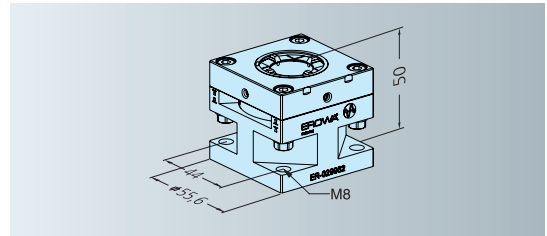

ER-020963 CompactChuck PM/PA



Version	On 106 x 106 mm clamping plate.
Connections	On the side on clamping plate.
Application	On milling, grinding and EDM centers with manual operation.

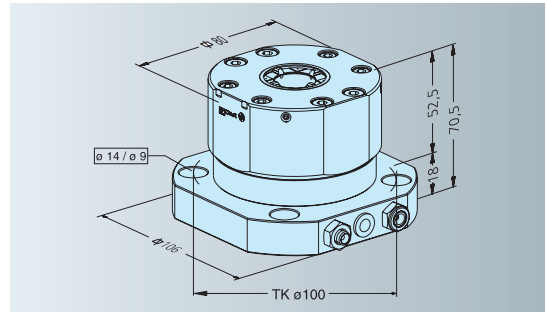

EROWA ITS Compact Combi

Compact ITS Adapter

ER-020487 Compact ITS adapter

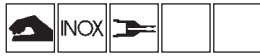

Version ITS system size 50, lock with central locking bolt. Prepared to accommodate chip holder for EWIS chip.

Operation Tighten central locking bolt.

Application System adapter Compact - ITS.

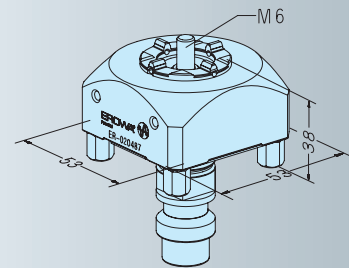

ER-029985 Compact ITS adapter chuck



Version ITS system size 50, QuickChuck action for Compact holders.

Operation Quick locking mechanism with lever.

Application Individual Compact chuck for machines which are equipped with standard ITS. System adapter Compact - ITS.

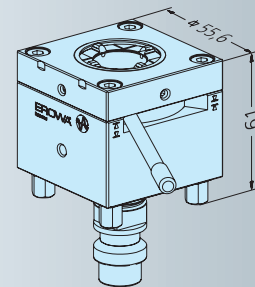

ER-029988 Compact ITS angle adapter



Version ITS System size 50, QuickChuck locking mechanism of 90° angle chuck.

Operation Quick locking mechanism with lever.

Application System adapter Compact - ITS.

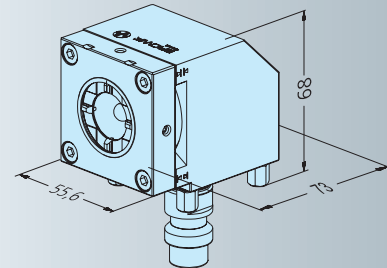

ER-036272 Compact ITS Adapter ø 72



Version ITS system size 50 ø 72. Lock with central locking bolt. Prepared for chip holder identification system.

Operation Tighten central locking bolt.

Application System adapter Compact - ITS 50 ø 72 mm.

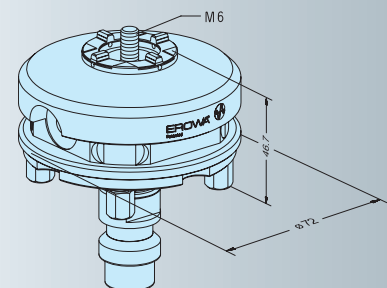

EROWA ITS Compact Combi Electrode Holder

ER-017532 Compact Uniholder 18 pieces



Version Set of 18 units.
Without chucking spigot.
Application To hold blanks up to 8 mm width.
To fit blank Insert and tighten M5 bolts.

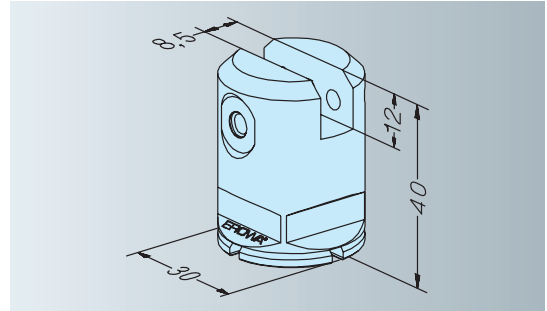

ER-017529 Compact Prisround 10 mm 18 pieces

ER-017530 Compact Prisround 15 mm 18 pieces



Version Set of 18 units.
Without chucking spigot.
Application To hold blanks with shaft of up to X = 10 mm square (ER-017529), up to X = 15 mm square (ER-017530).
Mounting Insert and tighten M5 bolts.

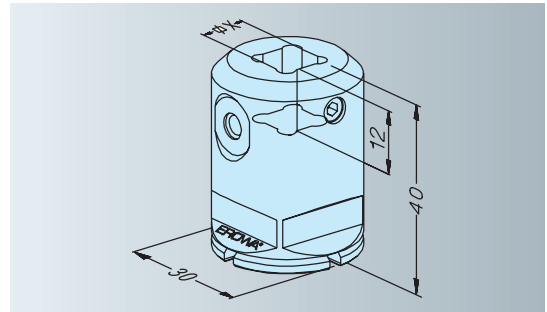

ER-034045 Compact Collet Chuck Holder 1 piece



Version One unit.
Application To hold cylindrical parts with respective diameter.
Please note Order collect chucks ER 16 (no INOX) separately.

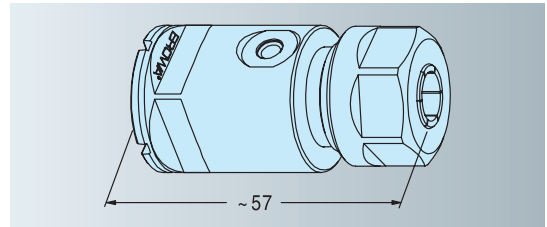

ER-002394 Collet chuck ER16 ø 2 mm

ER-002395 Collet chuck ER16 ø 3 mm

ER-002396 Collet chuck ER16 ø 4 mm

ER-002397 Collet chuck ER16 ø 5 mm

ER-002398 Collet chuck ER16 ø 6 mm

ER-002399 Collet chuck ER16 ø 7 mm

ER-002400 Collet chuck ER16 ø 8 mm

ER-002401 Collet chuck ER16 ø 9 mm

ER-002402 Collet chuck ER16 ø 10 mm



Version Clamping range 1 mm per collet chuck. Fits Collet Chuck Holder ER-017531.

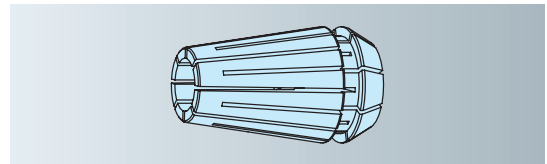

ER-017533	Compact Electrode Holder 8 mm 18 pieces
ER-017534	Compact electrode holder 10 mm 18 pieces
ER-017535	Compact electrode holder 12 mm 18 pieces
ER-017536	Compact electrode holder 16 mm 18 pieces



Version Set of 18 units.
 Without chucking spigot.
 Application To hold cylindrical parts with respective diameter.
 Mounting Insert and tighten M5 bolts.

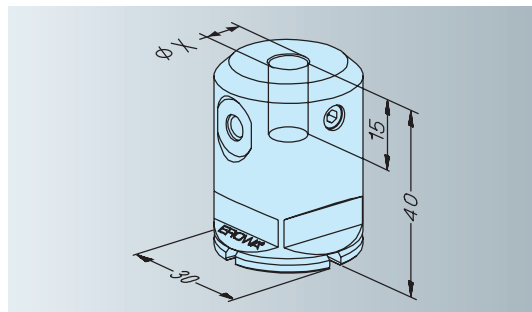

EROWA ITS Compact Combi Electrode

ER-019512 Compact electrode \varnothing 30 x 60
12 pieces, without gripper groove



Version Electrode copper.
Set of 18 units. Without chucking spigot.
Application To produce electrodes up to \varnothing 30 mm.

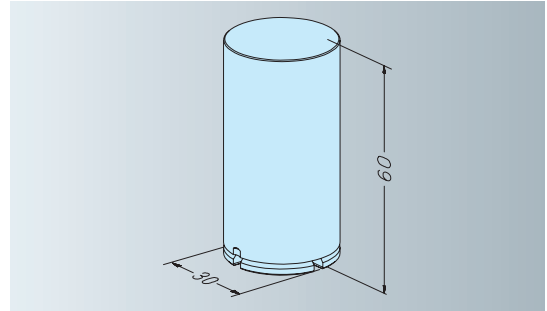

ER-030161 Compact electrode 10 x 10 x 45 copper
36 pieces



Version Electrode copper. Set of 36.
Application Production of electrodes of up to 10 x 10 mm.

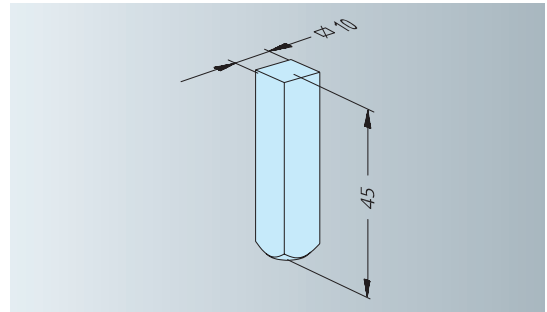

EROWA ITS Compact Combi Accessories

ER-017982 Compact extension 100 mm



Version Shaft \varnothing 30 x 100 mm.
Application Extends the electrode by 100 mm.
Operation Lock via central bolt through shaft.

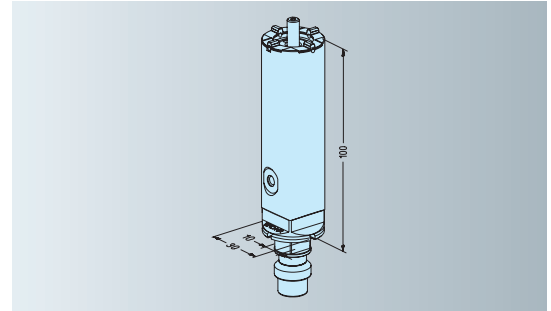

ER-017984 Compact angle chuck



Version Compact Chuck at 90° angle.
Operation Central locking bolt.
Application Change from vertical to horizontal machining position.

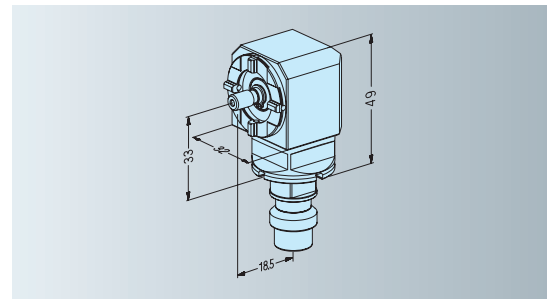

ER-029015 Compact standard holder H=16 20 pieces



Version Set of 20 per package, without chucking spigot.
Application To fit electrodes and workpieces.
Note Attach blank through the center with the chucking spigot bolt or through the holder with four M4 bolts (option ER-023125, 100 M4 x 14 socket head bolts).

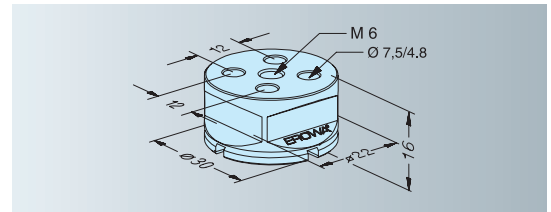

ER-029098 Chucking spigot Compact Combi 20 pieces



Version Set of 20.
Application To accommodate all the compact electrodes and electrode holders in CompactChucks, ITS-Compact-CombiChucks and electrode changers. For handling with the EROWA Combi gripper.

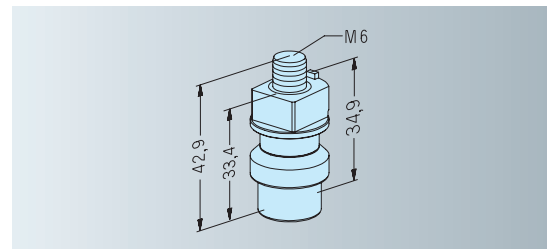

EROWA ITS Compact Combi Accessories

ER-051968 Chucking spigot clip 2 open electroconductive / 20 pieces



Version Synthetic, set of 20. Electroconductive.
To be fitted to ITS chucking spigot F/A.
Application To fit on ITS chucking spigot F/A. To load/unload ITS electrodes and electrode holders with EROWA Combi gripper.

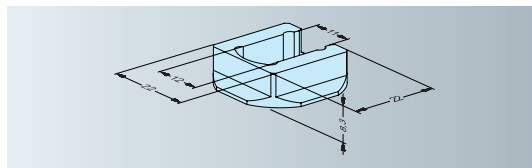

ER-051969 Chucking spigot clip 2 closed electroconductive / 20 pieces



Version Synthetic, set of 20. Electroconductive.
To be fitted to ITS chucking spigot F/A.
Application To fit to ITS chucking spigot F/A. To load/unload ITS electrodes and electrode holders with EROWA Combi gripper.

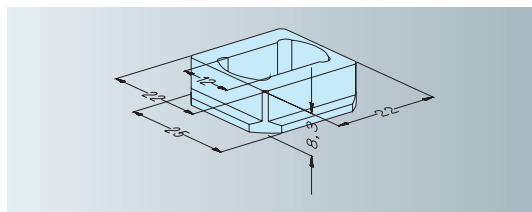

ER-020958 Compact system stand 24-fold 10 pieces

Version Styrene, set of 10.
Application Storage and transport of 24 parts each. Compact electrodes \varnothing 30 mm, with fitted Compact chucking spigot.

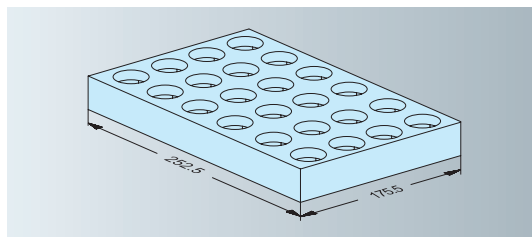

ER-022045 System stand Compact Combi 10 pieces

Version Plastic, set of 10.
Application Storage of 9 parts each. Compact electrodes with fitted Compact chucking spigot Combi.
Note The system stands can be fitted together to fill an entire surface, i.e. that of a drawer.

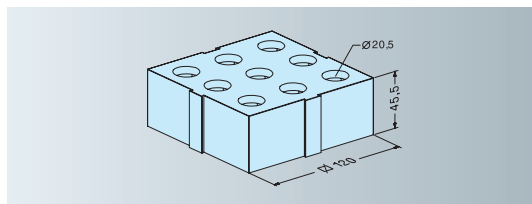

ER-035154 EWIS™ Rapid chip with chip holder SW14 with chip \varnothing 12,4 x 2 mm



Version Sleeve fitting with built-in datacarrier.
Application In any EROWA electrode holder and pallet which has been prepared for it.

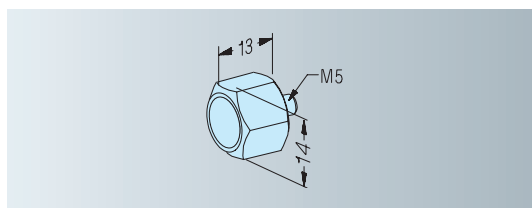

ER-008988 Manual control unit

- Version Manual valve to control all the functions of ITS, ITS Compact CombiChuck, PowerChuck P and UPC: opening/reclamping/cleaning.
- Application Operation of chucks on machines.

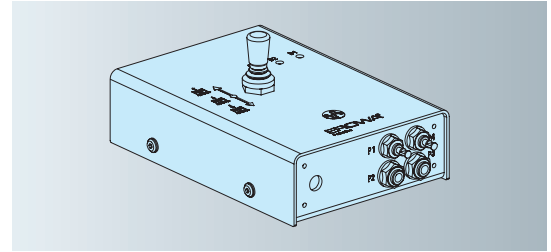
**ER-022921 Chip guard for CompactChuck 10 pieces**

- Version Rubber seal to attach to Compact ITS adapters. Set of 10.
- Application Protects Compact ITS adapter and prevents the intrusion of liquids and chips. To be used in combination with sealing ring ER-022922.

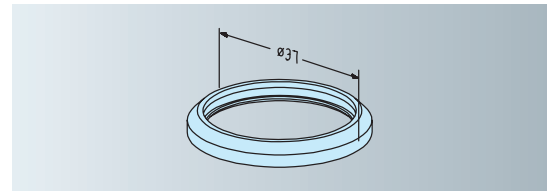
**ER-022923 Chip guard for CombiChuck 10 pieces**

- Version Plastic seal, set of 10.
- Application Protects Compact chucks and prevents the intrusion of liquids and chips. To be used in combination with sealing ring ER-022922 or Combi sealing ring ER-022924.

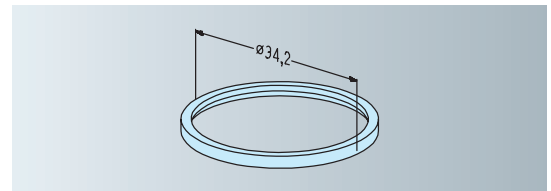
**ER-022922 Sealing ring for Compact holder 50 pieces**

- Version Rubber seal, set of 50.
- Application To be fitted to Compact holder. In combination with chip guards ER-022921 or ER-022923, this prevents the intrusion of liquids and chips into the CompactChuck and the CombiChuck.

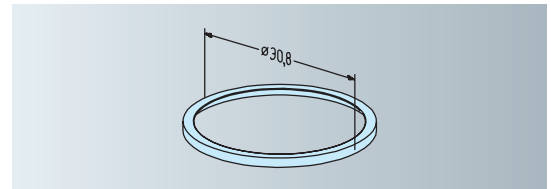
**ER-022924 Combi sealing ring / ITS chucking spigot 20 pieces**

- Version Plastic seal, set of 20.
- Application To be fitted to ITS chucking spigots. In combination with the chip guard ER-022923, this prevents the intrusion of liquids and chips into the CombiChuck.

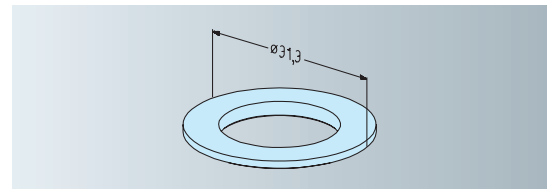

EROWA ITS Compact Combi

Measuring equipment

ER-019979 Compact centering equipment fixed



- Version Holder with slide and metric dial gauge.
Gradation: 0.01 mm.
- Application Centric alignment of workpieces on machines with C-axes or rotation spindles.

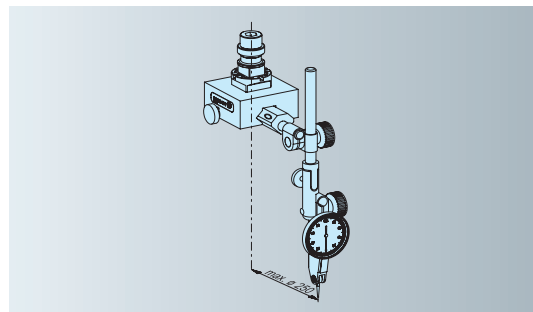

ER-019951 Compact centering equipment rotate



- Version Holder with slide and metric dial gauge.
Gradation: 0.01 mm.
- Application Centric alignment of workpieces on machines without rotation axis.

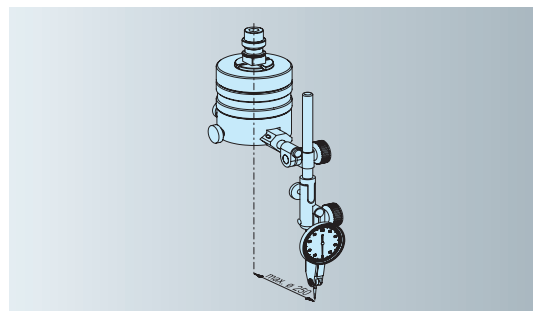

ER-017541 Compact checking pin



- Version Hardened, ground, corrosion-resistant.
- Application To align radial, axial and angular position of Compact chucks.

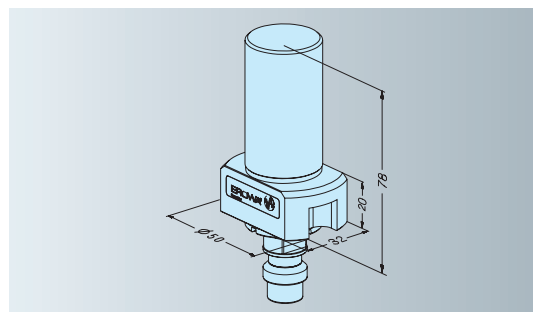

ER-019473 Compact probe with ball \varnothing 2 mm

ER-019474 Compact probe with ball \varnothing 5 mm



- Version Version with spring-mounted probe and carbide bolt.
Overrun protection: X-, Y-, Z-axes, 0.3 mm.
Repeatability: X-, Y-, Z-axes, 0.002 mm.
- Application Automatic measuring of workpieces in CNC EDM centers.

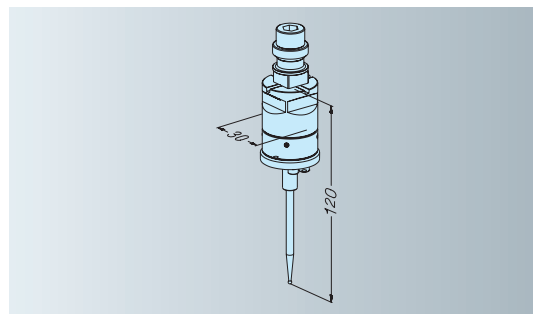

ER-032466 Compact Microscope



Version Magnification: 40x
Supply voltage: 12 Volt
Lighting: 6 Volt
Adapter: 110/220 Volt.

Application Determination of measurements on complicated contours.
The pointed checking pin serves to adjust the optic position.

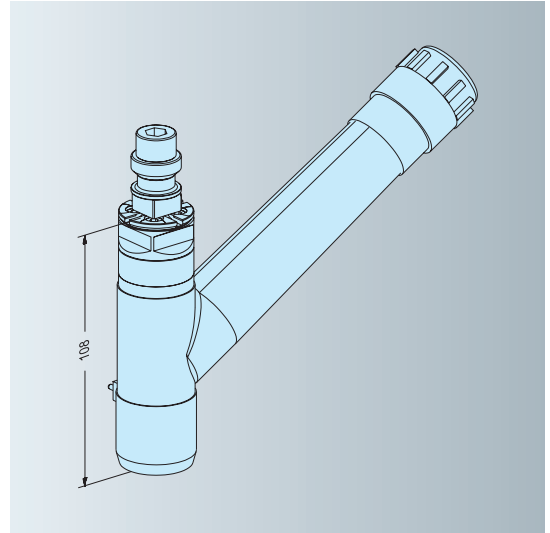

EROWA Compact Electrode holder Set

We have compiled a helpful set for the introduction of the EROWA Compact System. Additional material, in particular consumable parts, can be ordered according to your requirements.



ER-018858 Compact Electrode holder Set

The material is packed in a practical plastic box.

Article number	Description	Number of units in the set	Number supplied according to article number
000682	Stud bolt M5 x 8	4	1
018293	Stud bolt M5 x 10	12	1
018294	Stud bolt M5 x 6	16	1
ER-017529	Compact Prisround 10 mm	4	18
ER-017530	Compact Prisround 15 mm	4	18
ER-017532	Compact Uniholder	2	18
ER-017533	Compact Electrode holder \varnothing 8 mm	2	18
ER-017535	Compact Electrode holder \varnothing 12 mm	2	18
ER-017536	Compact Electrode holder \varnothing 16 mm	2	18
ER-029015	Compact Standard holder	6	20

Order chucking spigots according to requirements.